

Strömungserhitzer Flow heater



TÜV 99 ATEX 1478 Q

Explosionsschutz
Explosion proof



ELMESS

THERMOSYSTEMTECHNIK



- 1 Strömungserhitzer für flüssige und gasförmige Medien**
Flow Heater for liquid and gaseous mediums

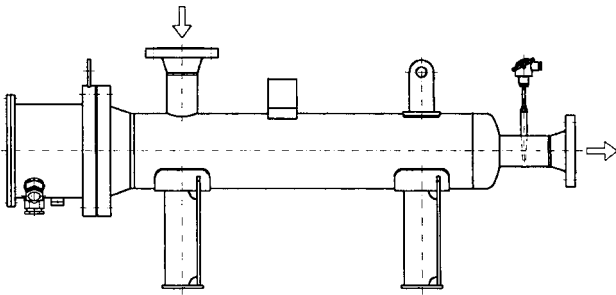

Baureihe I / Series I

- 2 Strömungserhitzer für hohe Mediumtemperaturen**
Flow Heater for high medium temperatures

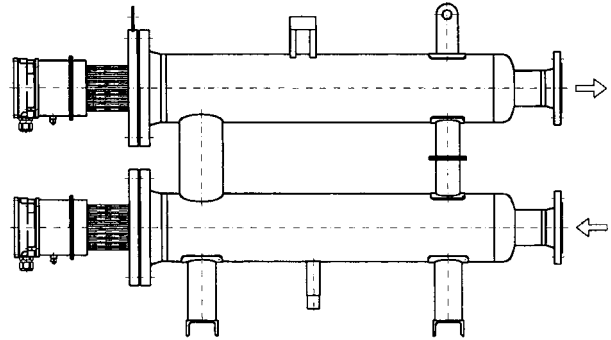

Baureihe I / Series I

- 3 Vorwärmer für Wasser, Heiz- und Schmieröl**
Preheater for water, fuel and lubrication oil

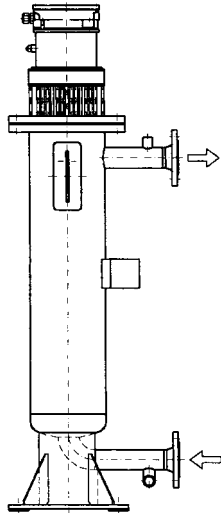

Baureihe I / Series I

- 4 Ölvorwärmer für Entnahme aus Lagertanks**
Oil preheater for extraction of storage tanks

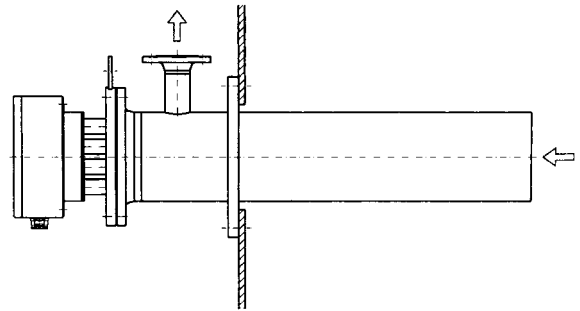

Baureihe I / Series I

- 5 Rohrschlangen Gasvorwärmer**
Tube coil gas preheater

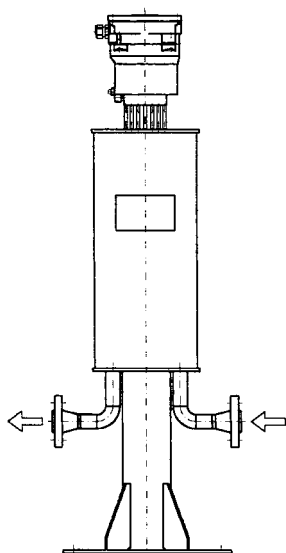

Baureihe III / Series III

- 6 Gasvorwärmer**
Gas preheater

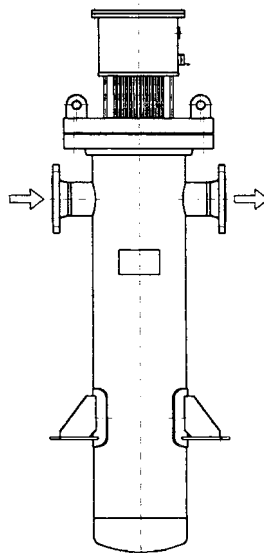

Baureihe II / Series II

- 7 Regeneriergasheizter**
Regeneration gas heater

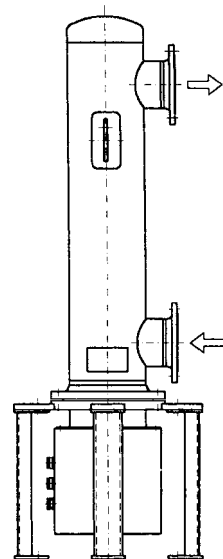

Baureihe I / Series I



Gasdruck-Regelstation mit Erdgasvorwärmer 35 kW, Baureihe III
Natural gas pressure regulation station with preheater 35 kW, series III



Erhitzer Abluftreinigungsanlage 141 kW, 3-stufig, 200 °C
Heater exhaust air plant 141 kW, 3 stages, 200 °C

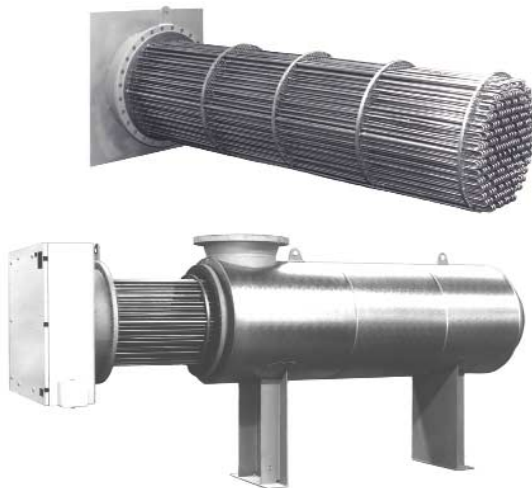

Regeneriergaserhitzer 790 kW, 350 °C, 3,75 bar
Regeneration gas heater 790 kW, 350 °C, 3,75 barg



Wasservorwärmer 120 kW mit komb. Schütz-/Thyristorsteuerung
Water preheater 120 kW with comb. contactor/thyristor control



Elektro-Dampferzeuger 50 kg/Stunde, 15 bar
Electric steam boiler 50 kg/hour, 15 barg



Fahrbarer Stickstoff-Erhitzer 7,5 kW, 290 °C, 4,5 bar für Tanktrocknung
Portable nitrogen heater 7,5 kW, 290 °C, 4,5 barg for tank drying